

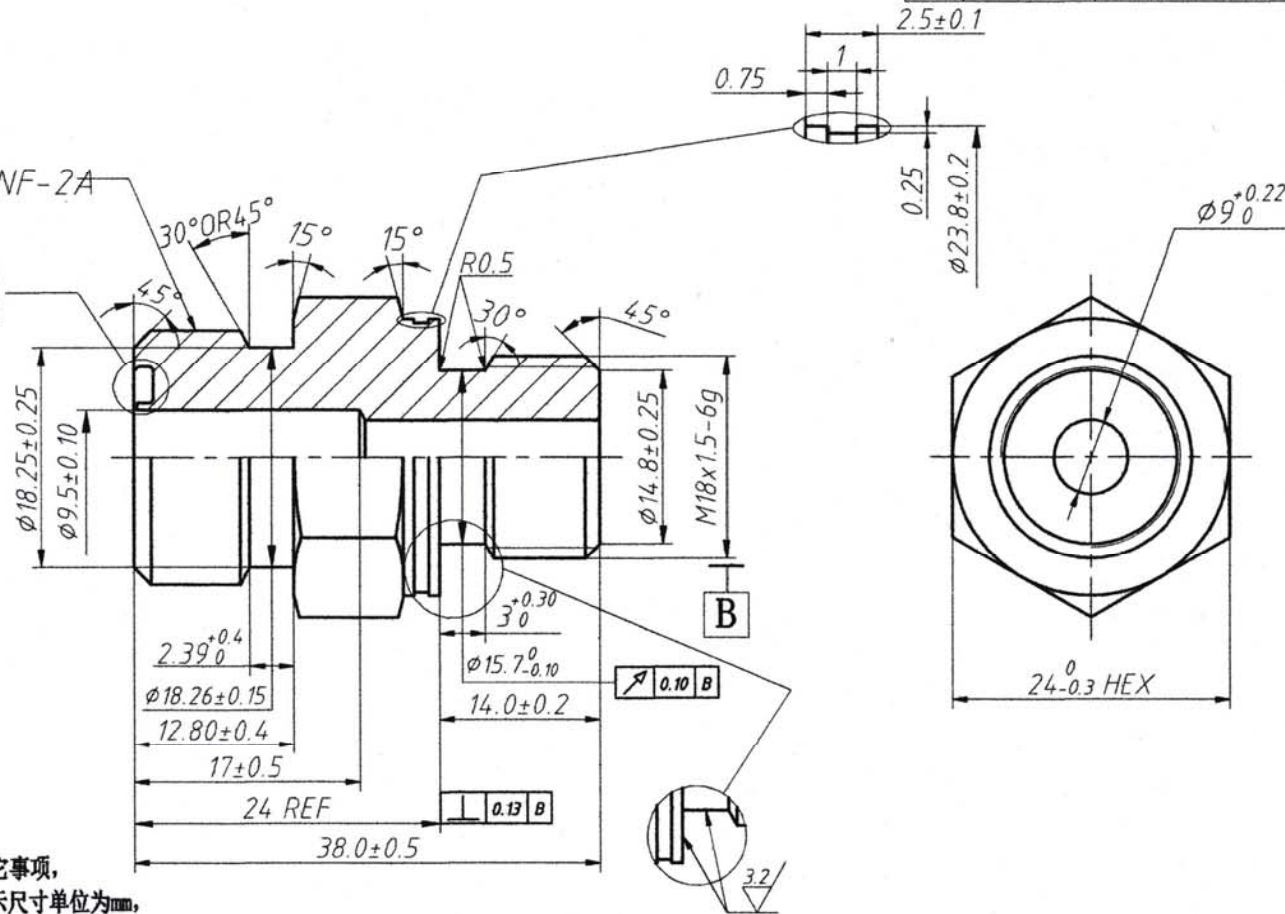

REV 更改号	DATE 日期	REVISION DETAILS 更改内容	APPD 审核并批准
A	JAN. 02. 2020	drawing update	
B	SEP. 28. 2022	change the part name from '6400-8FS-M18' TO '41666-STR-8FS-M18'	

SEE SAE J1453-1
REVISED MAY2012

$13/16-16\text{ UNF}-2A$



UNLESS SPECIFIED
ALL DIMENSIONS IN mm,
MACHINED SURFACES $Ra=3.2\mu m$,
ANGLE TOLERANCES $\pm 5^\circ$,
Other tolerance except angles,
in accordance with
GB/T1804-2000(ISO2768-1)-m
and GB/T1184-1996(ISO2768-2)-m

其它事项,
图示尺寸单位为mm,
未注机加工表面粗糙度 $Ra=3.2\mu m$,
未注角度公差 $\pm 5^\circ$,
其它未注公差 (除角度外) 均按:
GB/T1804-2000(ISO2768-1)-m 和
GB/T1184-1996(ISO2768-2)-m

Zhejiang Gaocheng Autoparts Co.,Ltd	
PART No 零件名	41666-STR-8FS-M18
SCALE:	APPD: 批准
NTS	DRN: 余德胜 制图 2022.09.28
	DATE: 日期
	CHK: 詹永斌 审核 2022.09.28

MATERIAL	Chinese steel 45	材质 45#
FINISH	Remove all sharp edges,burrs,slivers and swarf, break all edges 0.127-0.254mm. ZINC PLATING WITH 8um MICRONS MINIMUM PLATING THICKNESS AND TRIVALENT CHROMATE PASSIVATION AND WITHSTAND 96 HRS TO WHITE / 144 HS TO RED RUST IN SALT SPRAY TEST.	去除所有毛刺, 铁屑等残留物, 锐边倒钝0.127-0.254mm. 镀锌, 三价铬钝化, 银白色, 盐雾试验96小时无白斑, 144小时无红锈, 镀锌层厚度大于8um.